

*TB 9-6625-2361-24

DEPARTMENT OF THE ARMY TECHNICAL BULLETIN

CALIBRATION PROCEDURE FOR DIGITAL MULTIMETER FLUKE, MODEL 8502A WITH OPTIONS 02 AND 09A

Headquarters, Department of the Army, Washington, DC

10 October 2007

Distribution Statement A: Approved for public release; distribution is unlimited.

REPORTING OF ERRORS AND RECOMMENDING IMPROVEMENTS

You can improve this manual. If you find any mistakes or if you know of a way to improve these procedures, please let us know. Mail your letter or DA Form 2028 (Recommended Changes to Publications and Blank Forms) directly to: Commander, U.S. Army Aviation and Missile Command, ATTN: AMSAM-MMC-MA-NP, Redstone Arsenal, AL 35898-5000. A reply will be furnished to you. You may also send in your comments electronically to our E-mail address: 2028@redstone.army.mil or by fax 256-842-6546/DSN 788-6546. For the World Wide Web use: <https://amcom2028.redstone.army.mil>. Instructions for sending an electronic 2028 can be found at the back of this manual.

SECTION		Paragraph	Page
I.	IDENTIFICATION AND DESCRIPTION		
	Test instrument identification	1	2
	Forms, records, and reports	2	2
	Calibration description	3	2
II.	EQUIPMENT REQUIREMENTS		
	Equipment required.....	4	3
	Accessories required	5	4
III.	CALIBRATION PROCESS		
	Preliminary instructions	6	4
	Equipment setup.....	7	5
	DC voltage	8	5
	DC ratio	9	7
	AC voltage (option 09A).....	10	7
	Resistance (option 02).....	11	10
	Power supply	12	11
	Final procedure	13	13

*This bulletin supersedes TB 9-6625-2361-35, dated 13 April 2005.

**SECTION I
IDENTIFICATION AND DESCRIPTION**

1. Test Instrument Identification. This procedure provides instructions for the calibration of Digital Multimeter, Fluke, Model 8502A with Options 02 and 09A. The manufacturer’s manual was used as the prime data source in compiling these instructions. The equipment being calibrated will be referred to as the TI (test instrument) throughout this procedure.

a. Model Variations. None.

b. Time and Technique. The time required for this calibration is approximately 2 hours, using dc and low frequency technique.

2. Forms, Records, and Reports

a. Forms, records, and reports required for calibration personnel at all levels are prescribed by TB 750-25.

b. Adjustments to be reported are designated (R) at the end of the sentence in which they appear. When adjustments are in tables, the (R) follows the designated adjustment. Report only those adjustments made and designated with (R).

3. Calibration Description. TI parameters and performance specifications which pertain to this calibration are listed in table 1.

Table 1. Calibration Description

Test instrument parameters	Performance specifications		
Dc volts	Range: 0 to 1000 V		
	Accuracy: $\pm(\% \text{ of input} + \text{No. digits})$		
	Range	Normal resolution	High resolution
	100 mV	0.005 + 8	- - -
	1 V	0.004 + 1	0.004 + 9
	10 V	0.002 + 1	0.002 + 9
	100 V	0.004 + 1	0.004 + 9
Dc ratio	Range (external reference voltage): 0 to 40 V		
	Accuracy:		
	External reference voltage	Accuracy	
	± 20 to ± 40 V	$\pm(A+B+10\text{PPM})$	
	$\pm V_{\text{min}}$ to ± 20 V	$\pm(A+B+200\text{PPM})$ $V_{x\text{ref}}$	
A = 10 V range accuracy B = Input signal function and range accuracy V min = Minimum allowable external reference voltage determined as follows: $\pm 100 \mu\text{V}$ or a value found with the following formula (whichever is greater): $V_{\text{min}} = \frac{\pm V_{\text{in}}}{10^9}$ $V_{x\text{ref}}$ = Absolute value of external reference voltage			

Table 1. Calibration Description - Continued

Test instrument parameters	Performance specifications		
Ac volts True rms ac volts (option 09A)	Range: 0 to 1000 V Accuracy: \pm (% of reading + % of FS)		
	Frequency	% of input	% FS
	10 to 20 Hz	2.0	0.08
	20 to 50 Hz	1.0	0.04
	50 Hz to 10 kHz	0.2	0.04
	10 to 30 kHz	0.4	0.08
	30 to 50 kHz	0.6	0.6
	50 to 100 kHz	2.0	0.6
	100 to 300 kHz	2.8	1.0
	300 kHz to 1 MHz	3.7	2.1
NOTES:1. Slow filter must be used for full accuracy below 400 Hz. 2. Volt-hertz product not to exceed 2×10^7 for 100 V and 1000 V ranges and 1×10^7 for 1 V and 10 V ranges. 3. For inputs above 500 V, multiply accuracy by: $\frac{(2000V + V_{in})}{2000V}$			
Resistance (option 02)	Range: 10 Ω to 100 m Ω Accuracy: \pm (% of input + No. digits)		
	Range (Ω)	Normal resolution	High resolution
	10	0.01 + 20	- - -
	100	0.006 + 2	0.006 + 14
	1 k	0.006 + 1	0.006 + 8
	10 k	0.006 + 1	0.006 + 8
	100 k	0.006 + 1	0.006 + 8
	1 M	0.006 + 1	0.006 + 8
	10 M	0.04 + 1	0.04 + 8
	100 M	0.1 + 1	0.1 + 8

SECTION II EQUIPMENT REQUIREMENTS

4. Equipment Required. Table 2 identifies the specific equipment to be used in this calibration procedure. This equipment is issued with Secondary Transfer Calibration Standards Set AN/GSM-287 or AN/GSM-705. Alternate items may be used by the calibrating activity. The items selected must be verified to perform satisfactorily prior to use and must bear evidence of current calibration. The equipment must meet or exceed the minimum use specifications listed in table 2. The accuracies listed in table 2 provide a four-to-one ratio between the standard and TI. Where the four-to-one ratio cannot be met, the actual accuracy of the equipment selected is shown in parenthesis.

5. Accessories Required. The accessories required for this calibration are common usage accessories, issued as indicated in paragraph 4 above, and are not listed in this calibration procedure.

Table 2. Minimum Specifications of Equipment Required

		Manufacturer and model
--	--	------------------------

TB 9-6625-2361-24

Common name	Minimum use specifications	(part number)	
CALIBRATOR	Dc Volts: 100 mV to 1000 V Accuracy: 100 mV: ± 32.5 ppm 1 V, 100 V, 1000 V: ± 12.5 ppm 10 V: ± 7.25 ppm (± 8 ppm) Resistance: 10 Ω to 10 M Ω Accuracy: 10 Ω : ± 33 ppm 100 Ω : ± 20 ppm 1 k Ω to 100 k Ω : ± 17 ppm 1 M Ω : ± 17 ppm (± 23 ppm) 10 M Ω : ± 102 ppm 100 M Ω : ± 252 ppm	Fluke, Model 5720A (5720A) (p/o MIS-35947); w amplifier, Fluke 5725A/AR (5725A/AR)	
	Ac Volts		Frequency: \rightarrow (Hz) - Accuracy: \downarrow ($\pm\%$ of setting)
	2.5 mV		10 30 500 20 k 50 k 80 k 200 k 1 M
	1 V		---
	10 V		0.55 0.275 0.075 0.15 0.525 0.875 1.325 2.238
	100 V		0.54 0.27 0.07 0.14 0.45 0.8 1.2 1.975
	200 V		0.532 0.266 0.066 0.132 0.39 0.74 1.1 ---
	300 V		---
	500 V		---
	1000 V		---
DC VOLTAGE DIVIDER	Range: 0 to 1.0000000 Accuracy: ¹	ESI, Model RV722 (RV722)	
MULTIMETER	Range: 0 to 5.1 V dc Accuracy: $\pm 0.25\%$	Fluke, Model 8840A/AF05 (AN/GSM-64D)	

¹Combined accuracy of calibrator and dc voltage divider at 10 V dc is: ± 8.5 ppm.

**SECTION III
CALIBRATION PROCESS**

6. Preliminary Instructions

a. The instructions outlined in paragraphs 6 and 7 are preparatory to the calibration process. Personnel should become familiar with the entire procedure before beginning the calibration.

b. Items of equipment used in this procedure are referenced within the text by common name and item identification number as listed in table 2.

c. Unless otherwise specified, verify the result of each test and, whenever the test requirement is not met, take corrective action before continuing with the calibration. Adjustments required to calibrate the TI are included in this procedure. Additional maintenance information is contained in the manufacturer's manual for this TI.

d. When indications specified in paragraphs 8 through 11 are not within tolerance, perform the power supply check prior to making adjustments. After adjustments are made, repeat paragraphs 8 through 11. Do not perform power supply check if all other parameters are within tolerance.

- e. Unless otherwise specified, all controls and control settings refer to the TI.

7. Equipment Setup

WARNING

HIGH VOLTAGE is used or exposed during the performance of this calibration. DEATH ON CONTACT may result if personnel fail to observe safety precautions. REDUCE OUTPUT(S) to minimum after each step within the performance check where applicable.

- a. Remove protective cover from top of TI as required for adjustments. Adjustments are labeled on each module.
- b. Connect TI to a 115 V ac power source.
- c. Press TI **POWER ON/OFF** pushbutton to **ON** and allow at least 2 hours for warm-up and stabilization.

8. Dc Voltage

a. Performance Check

(1) Connect calibrator **OUTPUT HI, LO** and **V-GUARD** to TI **INPUT/ Ω SENSE HI, LO** and **GUARD**.

(2) Press TI **RANGE UP** or **DOWN** pushbutton to select range settings and set calibrator output to settings listed in table 3. If TI does not indicate within limits specified, perform **b** below.

NOTE

Digits inside parentheses, as shown in table 3 below, are exponents displayed when the TI **CAL** switch is in the UP position. Digits preceded by a dash, as shown in the adjustments, are the sixth digits displayed when the TI **CAL** switch is in the DOWN position.

Table 3. Dc Voltage

Test instrument range settings	Calibrator output settings	Test instrument indications	
		Min	Max
100 mV	100 mV	99.987 (-3)	100.013 (-3)
1 V	1 V	0.99995	1.00005
10 V	10 V	9.9997	10.0003
10 V ¹	10 V	-9.99971	-10.00029
10 V	-10 V	-9.99971	-10.00029
100 V ²	100 V	99.995	100.005
1000 V	1000 V	999.95	1000.05

¹Press TI **RANGE HI RES** pushbutton for a 6^{1/2} digit display.

²Press TI **RANGE HI RES** pushbutton for a 5^{1/2} digit display.

b. Adjustments

- (1) Set calibrator to **STANDBY** and disconnect from TI.
- (2) Press **RANGE DOWN** pushbutton to select 10 V manual range.
- (3) Lift **CAL** switch cover (tab) and slide **CAL** switch to **CAL MODE** (down). **PEAK** or **CAL** light will be on (flashing).
- (4) Short TI input terminals. If TI does not indicate 0.0000-0 ±1 digit, adjust A10A1R8 on A/D converter board to obtain 0.0000-0 indication. Remove short.
- (5) Connect calibrator **OUTPUT HI, LO** and **V-GUARD** to TI **INPUT/Ω SENSE HI, LO** and **GUARD**.
- (6) Set calibrator for a 10.1 V output. Adjust R1 (POS. CAL) on A/D converter board for a TI indication between +10.0999-9 and +10.1000-1 V (R).
- (7) Set calibrator for a -10.1 V output. Adjust R2 (NEG. CAL) on A/D converter board for a TI indication between -10.0999-9 and -10.1000-1 V (R).
- (8) Set calibrator for a 500 mV output. Adjust A10A1R7 on A/D converter board for a TI indication between +0.4999-9 and +0.5000-1 V (R).
- (9) Set calibrator for a 5 V output. Adjust A10A1R6 on A/D converter board for a TI indication between +5.0999-9 and +5.1000-1 V (R).
- (10) Set calibrator for a 2.6 V output. Adjust A10A1R5 on A/D converter board for a TI indication between +2.5999-9 and +2.6000-1 V (R).
- (11) Set calibrator for a 1.4 V output. Adjust A10A1R4 on A/D converter board for a TI indication between +1.3999-9 and +1.4000-1 V (R).
- (12) Set calibrator for a 750 mV output. Adjust A10A1R3 on A/D converter board for a TI indication between +0.7499-9 and +0.7500-1 V (R).
- (13) Repeat (6) through (12) above as necessary.
- (14) Press TI **RANGE DOWN** pushbutton to select 100 mV range.
- (15) Set calibrator for a 0 V output. Adjust A8R53 on dc signal conditioner board for a TI indication of 0 +0 μV.

(16) Set calibrator for a 300 mV output. Adjust A8R49 on dc signal conditioner board for a TI indication between +299.999 and +300.001 (R).

(17) Press **TI RANGE UP** pushbutton to select 1 V range.

(18) Set calibrator for a 2.5 V output. Adjust A8R48 on dc signal conditioner board for a TI indication between +2.49999-9 and +2.50000-1 V (R).

(19) Press **TI RANGE UP** pushbutton to select 100 V range.

(20) Set calibrator for a 100 V output. Adjust A8R47 on dc signal conditioner for a TI indication between 99.999-9 and 100.000-1 V (R).

(21) Lift **CAL** switch cover (tab) and slide **CAL** switch out of **CAL MODE** (up). **PEAK ON CAL** light will be off (not flashing).

9. Dc Ratio

a. Performance Check

- (1) Connect equipment as shown in figure 1.
- (2) Press **VDC FUNCTION** and **AUTO RANGE** pushbuttons.
- (3) Set dc voltage divider dials to **.999999X**.
- (4) Set calibrator for 10 V dc output.
- (5) Press and hold **EXT REF** pushbutton. TI will indicate between 9.9998 and 10.0002 V.
- (6) Release **EXT REF** pushbutton. TI will indicate between 0.9996 and 1.00004 V.
- (7) Set dc voltage divider dials to **0.1000000**. TI will indicate between 99.995 and 100.005 mV.
- (8) Press **EXT REF** pushbutton to toggle **TI** out of the external reference mode.

b. Adjustments. No adjustments can be made.

10. Ac Voltage (Option 09A)

a. Performance Check

(1) Simultaneously press **VDC** and **VAC FUNCTION** pushbuttons (both indicators will illuminate).

(2) Select the **10 V** manual range and short **INPUT HI-LO** terminals. If TI does not indicate $0 \pm 30 \mu\text{V}$, perform **b** (1) through (3) below.

(3) Connect calibrator **OUTPUT HI** and **LO** to **TI INPUT/ Ω SENSE HI** and **LO**.

(4) Set calibrator for a -200 mV dc output. Record absolute value of TI indication.

(5) Set calibrator for a +200 mV dc output. Record absolute value of TI indication.

(6) If difference between absolute value of TI indications recorded in (4) and (5) above is not less than 10 digits, perform **b** (4) through (7) below.

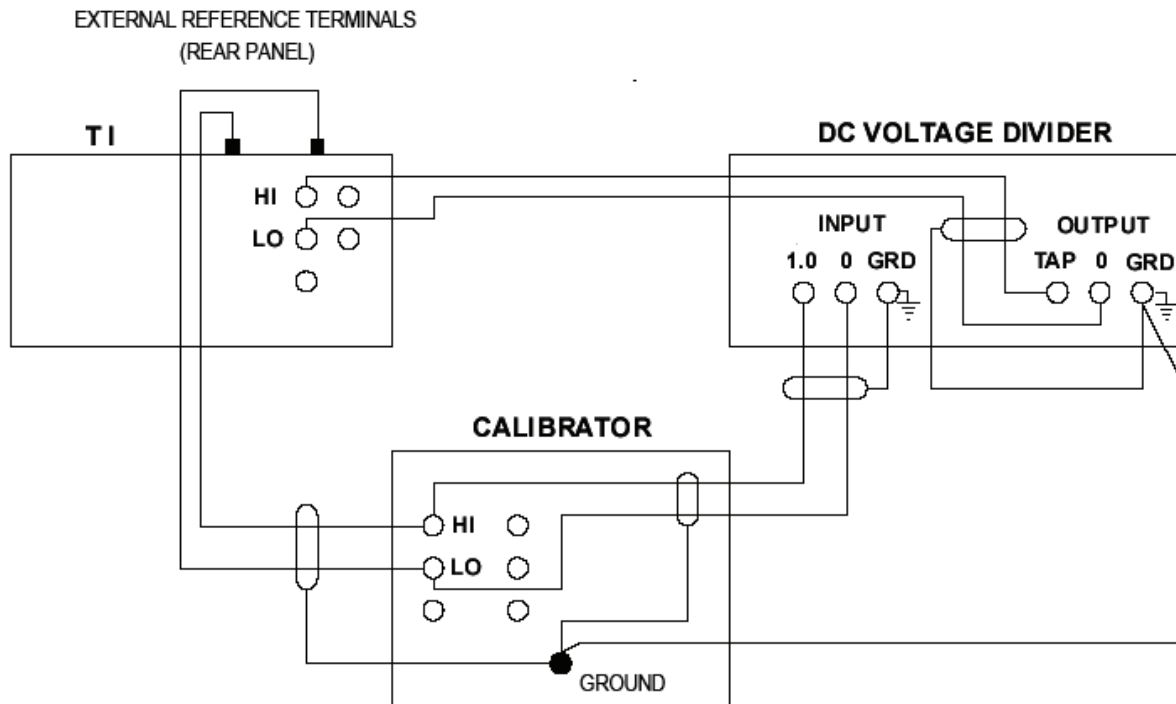

Figure 1. Dc ratio - equipment setup.

NOTE

The **CAL MODE** of operation prevents the TI from over-ranging during adjustments at the range upper limit. Ignore the CAL digit when performing remaining checks and adjustments.

- (7) Lift **CAL** switch cover (tab) and slide **CAL** switch to **CAL MODE** (down). **PEAK** or **CAL** light will be flashing.
- (8) Set calibrator for a -20.0 V dc output. Record absolute value of TI indication.
- (9) Set calibrator for a +20.0 V dc output. Record absolute value of TI indication.
- (10) If difference between absolute value of TI indications recorded in (8) and (9) above is not less than 10 digits, perform **b** (8) through (11) below.
- (11) Set calibrator **OPR/STBY** to **STBY**.
- (12) Press **FUNCTION VAC** pushbutton and select the 1V manual range.
- (13) Set calibrator output to 2.5 mV at 500 Hz. If TI does not indicate between 0.00211 and 0.00288 V, perform **b** (12) below.
- (14) Repeat technique of (12) and (13) above using settings and indications listed in table 4. If TI does not indicate within limits specified, perform corresponding adjustments.
- (15) Lift **CAL** switch (tab) and slide **CAL** switch out of **CAL MODE** (up).

Table 4. Ac Voltage

Test instrument range settings	Calibrator		Test instrument indications (V ac)		TI Adjustments
	Voltage (V ac)	Frequency (Hz)	Min	Max	
1 ¹	1	10 Hz	0.978	1.022	---
1	1	30 Hz	0.989	1.011	---
1 ²	1	500 Hz	0.997	1.003	b(13)
1	1	20 k	0.994	1.006	---
1	1	50 k	0.979	1.021	b(14)
1	1	80 k	0.965	1.035	---
1	1	200 k	0.947	1.053	---
1	1	1 M	0.9105	1.0895	b(15)
10	10	1 M	9.21	10.79	b(16)
10	10	200 k	9.52	10.48	---
10	10	80 k	9.68	10.32	---
10	10	50 k	9.82	10.18	b(17)
10	10	20 k	9.944	10.056	
10	10	500 Hz	9.972	10.028	b(18)
10 ¹	10	30 Hz	9.892	10.108	---
10	10	10 Hz	9.784	10.216	---
100	100	10 Hz	97.872	102.128	---
100	100	30 Hz	98.936	101.064	---
100 ²	100	500 Hz	99.736	100.264	b(19)
100	100	20 k	99.472	100.528	---
100	100	50 k	98.44	101.56	b(20)
100	100	80 k	97.04	102.96	---
100	100	200 k	95.6	104.4	---
1000	1000	500 Hz	996.4	1003.6	b(21)
1000	1000	20 k	992.8	1007.2	---
1000	500	50 k	491.0	509.0	b(22)
1000	300	80 k	288.0	312.0	---
1000	200	200 k	190.0	210.0	---

¹Set slow filter on.

²Set slow filter off.

b. Adjustments

NOTE

All adjustments are located on the ac/dc converter board.

- (1) Connect multimeter **INPUT HI** to TI TP5 and **LO** to TI TP1.
- (2) Select the 10 V manual range and short TI **INPUT HI** and **LO**.
- (3) Adjust R12 RANGE ZERO for a 0 ±30 μV multimeter indication. Remove short.
- (4) Set calibrator for a -200 mV dc output. Record absolute value of TI indication.
- (5) Set calibrator for a +200 mV dc output. Record absolute value of TI indication.
- (6) Adjust R42 BALANCE ZERO until the difference between the absolute values recorded in (4) and (5) above is less than 10 digits.
- (7) Repeat (4) through (6) above as necessary.

TB 9-6625-2361-24

- (8) Set calibrator for a -20 V dc output. Record absolute value of TI indication.
- (9) Set calibrator for a +20 V dc output.
- (10) Adjust R32 BALANCE GAIN to the absolute value recorded in (8) above (R).
- (11) Repeat (8) through (10) above until the difference between the absolute values is less than 10 digits without adjustments.
- (12) Adjust R45 AC ZERO for a TI indication of 0.00250 V (R).
- (13) Set calibrator for 500 Hz and 2.5 V output. Adjust R14 for a TI indication of 2.50000 V (R).
- (14) Set calibrator for 50 kHz and 2.5 V output. Adjust C9 for a TI indication of 2.50000 V (R).
- (15) Set calibrator for 1 MHz and 1.0 V output. Adjust R75 for a TI indication of 1.00000 V (R).
- (16) Set calibrator for 1 MHz and 10.0 V output. Adjust R75 for a TI indication of 10.0000 V (R).

NOTE

Adjust R75 for best in-tolerance condition for (15) and (16) above.

- (17) Set calibrator for 50 kHz and 20.0 V output. Adjust C11 for a TI indication of 20.0000 V (R).
- (18) Set calibrator for 500 Hz and 20.0 V output. Adjust R16 for a TI indication of 20.0000 V (R).
- (19) Set calibrator for 500 Hz and 160.0 V output. Adjust R18 for a TI indication of 160.000 V (R).
- (20) Set calibrator for 50 kHz and 160.0 V output. Adjust C14 for a TI indication of 160.000 V (R).
- (21) Set calibrator for 500 Hz and 500.0 V output. Adjust R64 for a TI indication of 500.00 V (R).
- (22) Set calibrator for 50 kHz and 500.0 V output. Adjust C4 for a TI indication of 500.00 V (R).

11. Resistance (Option 02)

a. Performance Check

- (1) Connect calibrator **OUTPUT HI** and **LO** to **TI INPUT VOLTS/ Ω SENSE HI** and **LO**.
- (2) Connect calibrator **SENSE HI** and **LO** to **TI INPUT AMPS/ Ω SOURCE HI** and **LO**.
- (3) Press **TI FUNCTION OHMS** pushbutton.
- (4) Press **RANGE UP** or **DOWN** pushbutton to select 10 Ω range.
- (5) Set calibrator for a 0 Ω output, **EX SNS** on.
- (6) Press **TI ZERO V DC/ Ω** pushbutton (**ZERO** annunciator off).
- (7) Allow TI to take at least one measurement then press **ZERO V DC/ Ω** pushbutton (**ZERO** annunciator on).

(8) Set calibrator for a 10 Ω output then, using output adjustment controls, set calibrator control display **Reading** equal to TI indication. If calibrator control display **Error** does not indicate within ±0.03%, perform **b** (1) below.

(9) Repeat technique of (4) through (8) above for TI range and calibrator output settings listed in table 5. If calibrator control display **Error** indication is not within limits specified, perform corresponding adjustment.

Table 5. Resistance

Test instrument range settings	Calibrator		Adjustments
	Output settings	Control display Error indications (±%)	
100 Ω	100 Ω	0.008	- - -
1 kΩ	1 kΩ	0.007	b(2)
10 kΩ	10 kΩ	0.007	- - -
100 kΩ	100 kΩ	0.007	b(3)
1 MΩ	1 MΩ	0.007	b(4)
10 MΩ	10 MΩ	0.041	- - -

(10) Set calibrator for a 0 Ω output, **EX SNS** off.

(11) Move TI **INPUT AMPS/Ω SOURCE HI** and **LO** connections from calibrator **SENSE HI** and **LO** to calibrator **OUTPUT HI** and **LO**.

(12) Press **RANGE UP** pushbutton to select 100 MΩ range and repeat (6) and (7) above.

(13) Set calibrator for a 100 MΩ output then, using output adjustment controls, set calibrator control display **Reading** equal to TI indication. If calibrator control display **Error** does not indicate within ±0.101%, perform **b** (5) below.

b. Adjustments

(1) Adjust R24 until TI indication is equal to calibrator output display value rounded to TI display resolution (R).

(2) Adjust R54 until TI indication is equal to calibrator output display value rounded to TI display resolution (R).

(3) Adjust R44 until TI indication is equal to calibrator output display value rounded to TI display resolution (R).

(4) Adjust R40 until TI indication is equal to calibrator output display value rounded to TI display resolution (R).

(5) Adjust R37 until TI indication is equal to calibrator output display value rounded to TI display resolution (R).

12. Power Supply

a. Performance Check

NOTE

Do not perform power supply check if all other parameters are within tolerance.

TB 9-6625-2361-24

- (1) Press **POWER ON OFF** pushbutton to **OFF**.
- (2) Replace isolator or bus interconnect board, whichever is installed, with bus interconnect and monitor board, MIS-7013K. Remove **CAL** memory if installed.
- (3) Connect multimeter **INPUT HI** to **Vcc** (fig. 2) and **LO** to **Vss** (fig. 2). Press **POWER ON OFF** pushbutton to **ON**. If multimeter does not indicate between 5.00 and 5.10 V dc, perform **b** (1) below.
- (4) Connect multimeter **INPUT HI** to **VA2** (fig. 2). If multimeter does not indicate between 5.00 and 5.10 V dc, perform **b** (2) below.

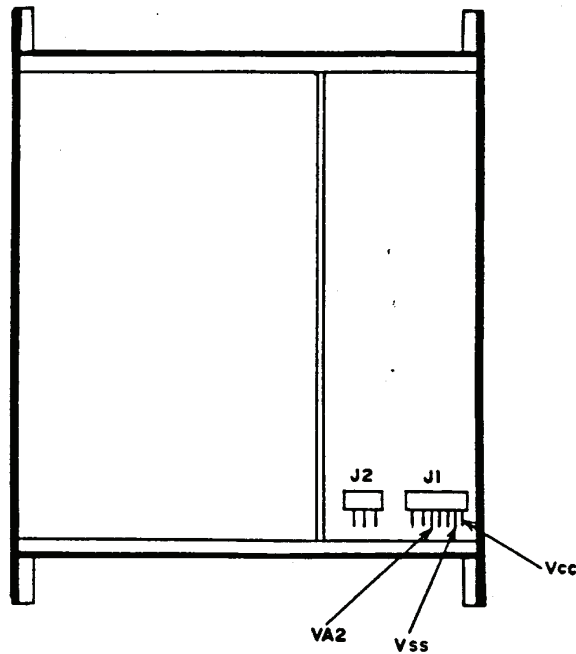
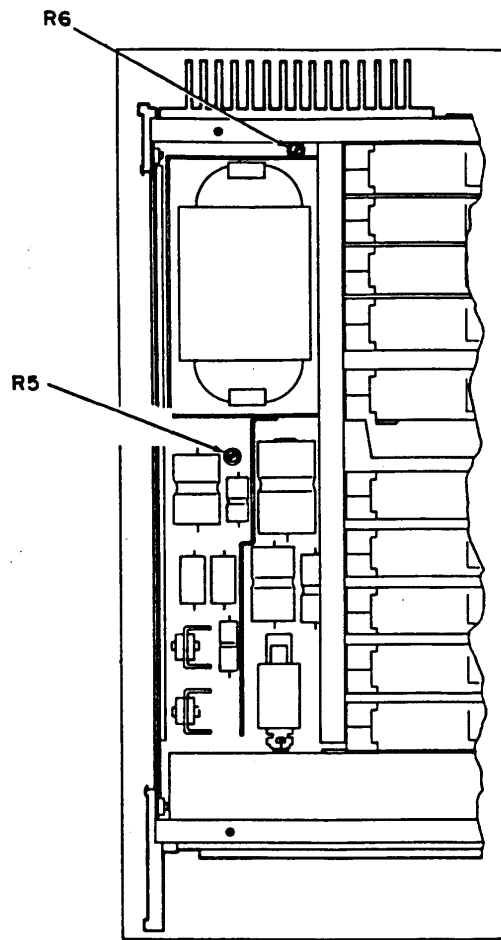

Figure 2. Test instrument - bottom view.

b. Adjustments

- (1) Adjust R6 (fig. 3) to obtain a + 5.05 V dc indication on multimeter (R).
- (2) Adjust R5 (fig. 3) to obtain a + 5.05 V dc indication on multimeter



(R).

Figure 3. Test instrument - right top view.

13. Final Procedure

- a. Deenergize and disconnect all equipment and reinstall protective cover on TI.
- b. Annotate and affix DA label/form in accordance with TB 750-25.

By Order of the Secretary of the Army:

Official:



JOYCE E. MORROW

*Administrative Assistant to the
Secretary of the Army*

0722105

GEORGE W. CASEY, JR.
*General, United States Army
Chief of Staff*

Distribution:

To be distributed in accordance with the initial distribution number (IDN) 344811, requirements for calibration procedure TB 9-6625-2361-24.

INSTRUCTIONS FOR SUBMITTING AN ELECTRONIC 2028

The following format must be used if submitting an electronic 2028. The subject line must be exactly the same and all fields must be included; however, only the following fields are mandatory: 1, 3, 4, 5, 6, 7, 8, 9, 10, 13, 15, 16, 17, and 27.

From: "Whomever" whomever@redstone.army.mil
To: <2028@redstone.army.mil

Subject: DA Form 2028

1. **From:** Joe Smith
2. **Unit:** home
3. **Address:** 4300 Park
4. **City:** Hometown
5. **St:** MO
6. **Zip:** 77777
7. **Date Sent:** 19-OCT -93
8. **Pub no:** 55-2840-229-23
9. **Pub Title:** TM
10. **Publication Date:** 04-JUL-85
11. **Change Number:** 7
12. **Submitter Rank:** MSG
13. **Submitter FName:** Joe
14. **Submitter MName:** T
15. **Submitter LName:** Smith
16. **Submitter Phone:** 123-123-1234
17. **Problem:** 1
18. **Page:** 2
19. **Paragraph:** 3
20. **Line:** 4
21. **NSN:** 5
22. **Reference:** 6
23. **Figure:** 7
24. **Table:** 8
25. **Item:** 9
26. **Total:** 123
27. **Text**

This is the text for the problem below line 27.

